



Steel Fuel Tanks... ...Features and Attributes

Peter Mould
Strategic Alliance for Steel Fuel Tanks (SASFT)



- For most of the history of the automobile, STEEL fuel tanks have been used
 - Effective container
 - Safe
 - Easily manufactured
 - Durable
 - Recycled
- In recent decades PLASTIC fuel tanks have emerged and grown market share
- Drivers, trends and improved features of the STEEL TANK are reviewed herein



- **Historical Perspective**
 - Steel and Plastic tanks
 - Market mix
 - Misperceptions about steel tanks
- **Current Market Requirements/Drivers for change**
- **Features and Attributes of Steel Tanks**
 - Cost competitiveness and availability
 - Design flexibility
 - Fuel Capacity
 - Mass
 - Durability
 - Corrosion Requirements
 - External/road environment
 - Internal/fuels
 - Fatigue
 - Evaporative Emissions
 - Sustainability/recycling



Historical Perspectives

- **Monolayer, HDPE plastic tanks** emerged in Europe in late 20th century

- Blow-molded
- Lower cost than steel
 - BUT *Highly permeable, allowing evaporative emissions*
Fluorination and sulphonation helped reduce emissions

- **Multilayer HDPE plastic tanks** were then developed

- Blow-molded
- Favored in North America (lower emissions, slosh noise control)
 - BUT *More complex structure/molding increased costs*
..... *Impact of rising oil prices*

- **Environmental issues (from 1990s)**

- Stricter regulations on evaporative emissions (EPA, CARB, Euro V)
 - EFFECT *More complex plastics/manufacturing increases plastic tank costs*
- Growing requirement for recycling (especially Europe)

- **Advent of alternative fuels**

- Alcohol-containing fuels (E10 to E100). *Impact on emissions and driving range*
- Bio-diesel fuels (B10 to B90). *Impact on durability*



Current Market Requirements (North America)

- **Competitive Costs**
- **Low Mass**
 - Driven by new fuel economy standards
- **Good Design Flexibility**
 - Limited engineering space requires complex shaped tanks
 - Influences fuel capacity/driving range
- **Durability**
 - CARB requires fully-functional fuel systems for 15 yrs
(150,000 miles)
 - Variety of fuels



Current Market Requirements (North America) (Continued)

- **Strict Evaporative Emission Requirements**
 - Driven by California Air Resources Board (CARB)
 - PZEV requirements (HC/24 hrs)
 - Full Vehicle: <0.35g
 - Fuel System: <0.054g
 - Fuel Tank: <0.015g (target set by OEMs)
 - Numerous USA states & Canada adopting CARB requirements
- **Alternative Fuels**
 - Impact on durability, evaporative emissions, driving range
- **Recycling** (important in Europe)



Future Market Shares

- Will be determined by how STEEL and PLASTIC tanks can meet changing requirements
 - Cost and Availability
 - Lower mass
 - Stricter evaporative emissions
 - Durability/compatibility with new fuels
 - Fuel Capacity
 - Likely reduced driving range with alcohol fuels
 - Future generation vehicles e.g. Hybrids
 - Recycling (EOL vehicle accountability)



Outdated Perceptions of Steel Fuel Tanks

- “Always more costly”
- “Less design flexibility”
- “Have higher mass”
- “Simple shapes minimize fuel capacity”
- “Steel rusts and corrodes”



*Based on new steels and tank manufacturing processes,
these are MISPERCEPTIONS and...*



Benefits of Steel Fuel Tanks

- Impermeability is ideal for meeting low evaporative emission requirements (e.g., PZEV)
- Highly formable steels & improved manufacturing allow:
 - Complex shapes
 - Increased fuel capacity
- New steel ‘systems’ are:
 - Resistant to external corrosion (beyond 15 yrs/150,000 miles)
 - Compatible with alternative fuels
 - Preferred for hybrid-vehicle tanks
- High rigidity for good shape stability





Cost Competitiveness

- As technical requirements for fuel tanks have increased, the cost competitiveness of steel tanks has increased.

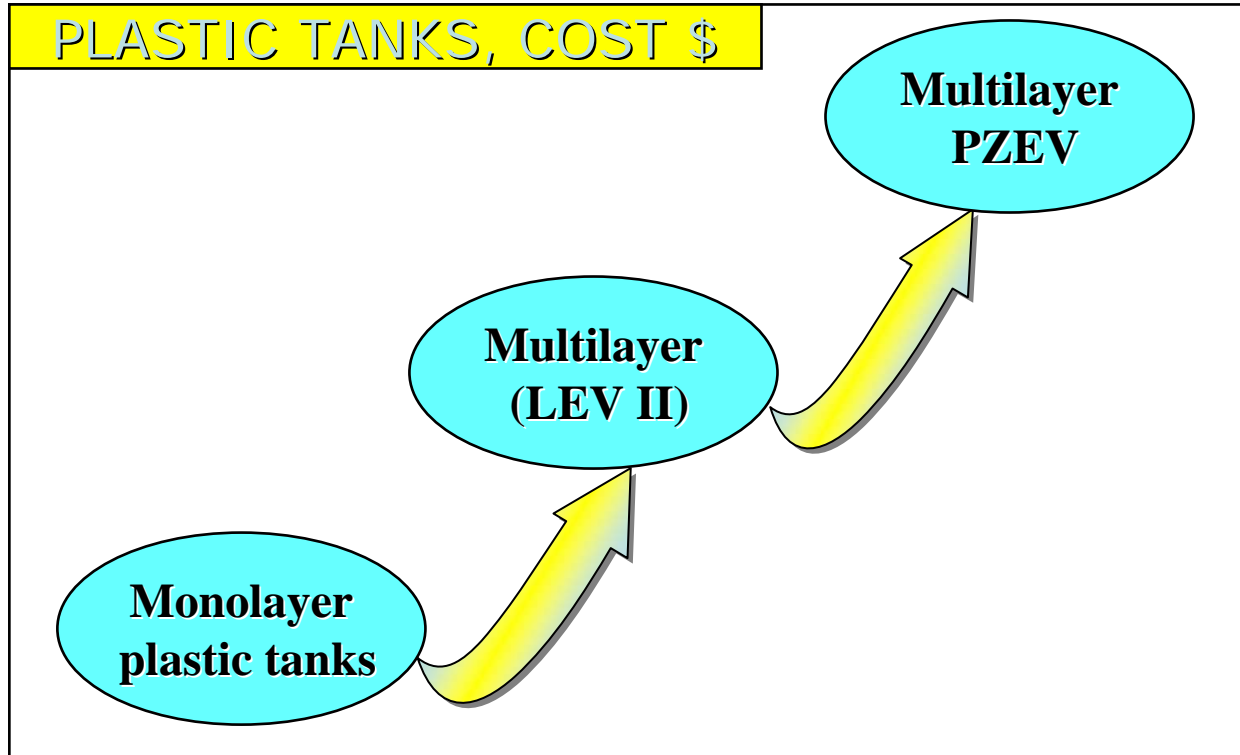



Cost Competiveness

- HDPE resin prices have been increasing much faster than steel

SASFT Materials Price Trends as of 02/15/2008

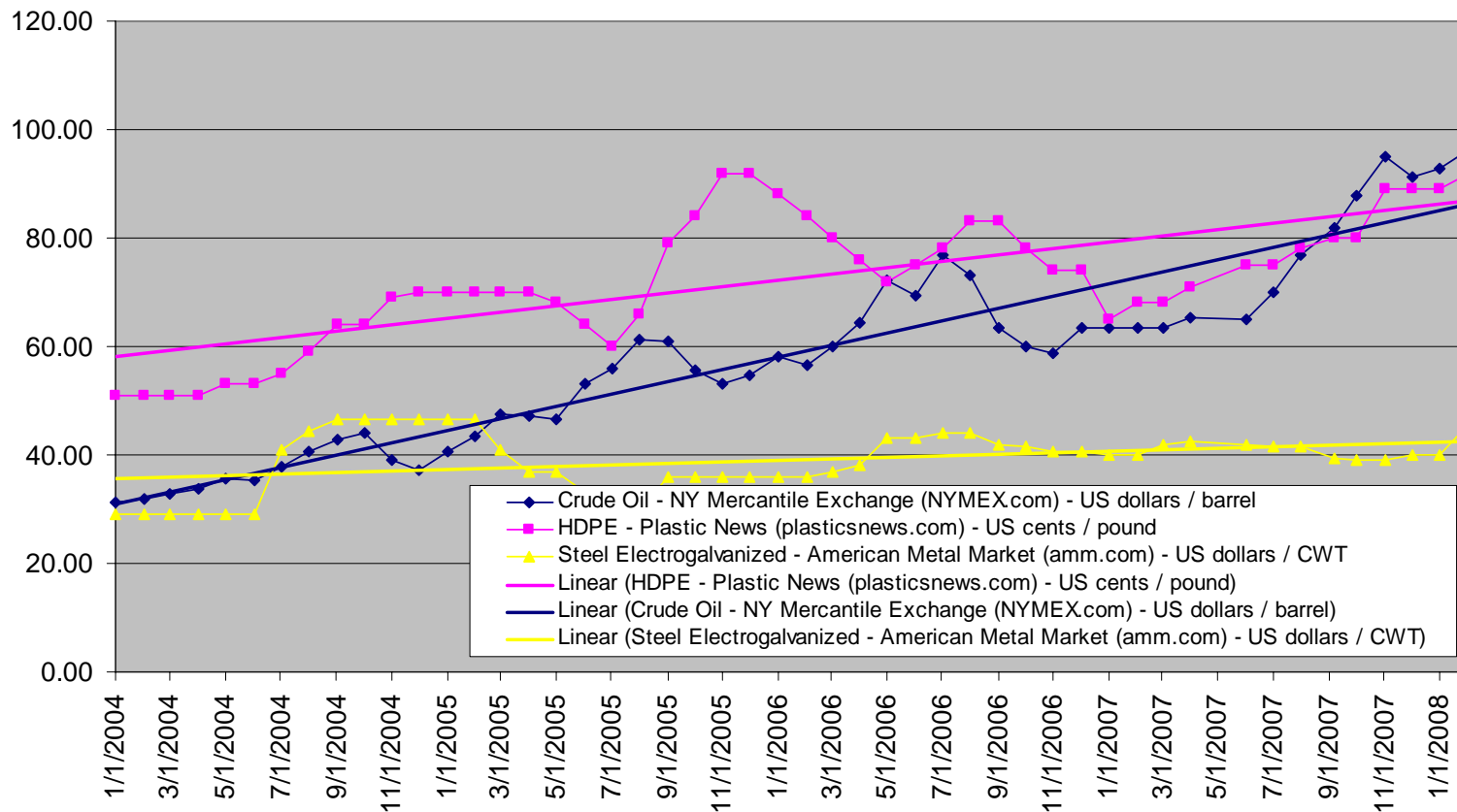



A Purchaser's View:

“... resin price has been going up”

“... a steel fuel tank can be welded together very close to the assembly plant and now you have reduced transportation cost and that is another key driver.”

Bo Anderson (GM Purchasing)

Interview with Design News, Nov. 27, 2007

An Editor's View:

“New steels (tanks) are increasingly formable allowing more design freedom and they are 100% recyclable. And they are increasingly cost competitive. With a landed cost approach and ballooning hydrocarbon prices, they are even preferred on a cost basis.”

Doug Smock (Contributing Editor)

Design News, Nov. 27, 2007



Cost Competitiveness

- Today steel tanks are very cost competitive
 - Especially for high technology tanks

The PERCEPTION of higher cost steel tanks is FALSE

- In the future
 - Geo-political uncertainty is likely to drive up oil and resin prices still further
 - Steel prices and steel's availability will be influenced much less by geo-political events



Design Flexibility

- Today's steels are formed to highly complex shapes



Ford Mustang



Mercedes Benz

The PERCEPTION that only simple shapes can be made in steel is FALSE.

... Two principal enablers



Enablers for Producing Complex-Shaped Steel Tanks

- **New highly formable steels**
 - Interstitial-free low carbon steels
 - Improved austenitic/ferritic stainless steel
 - Improved forming lubricants (water soluble)

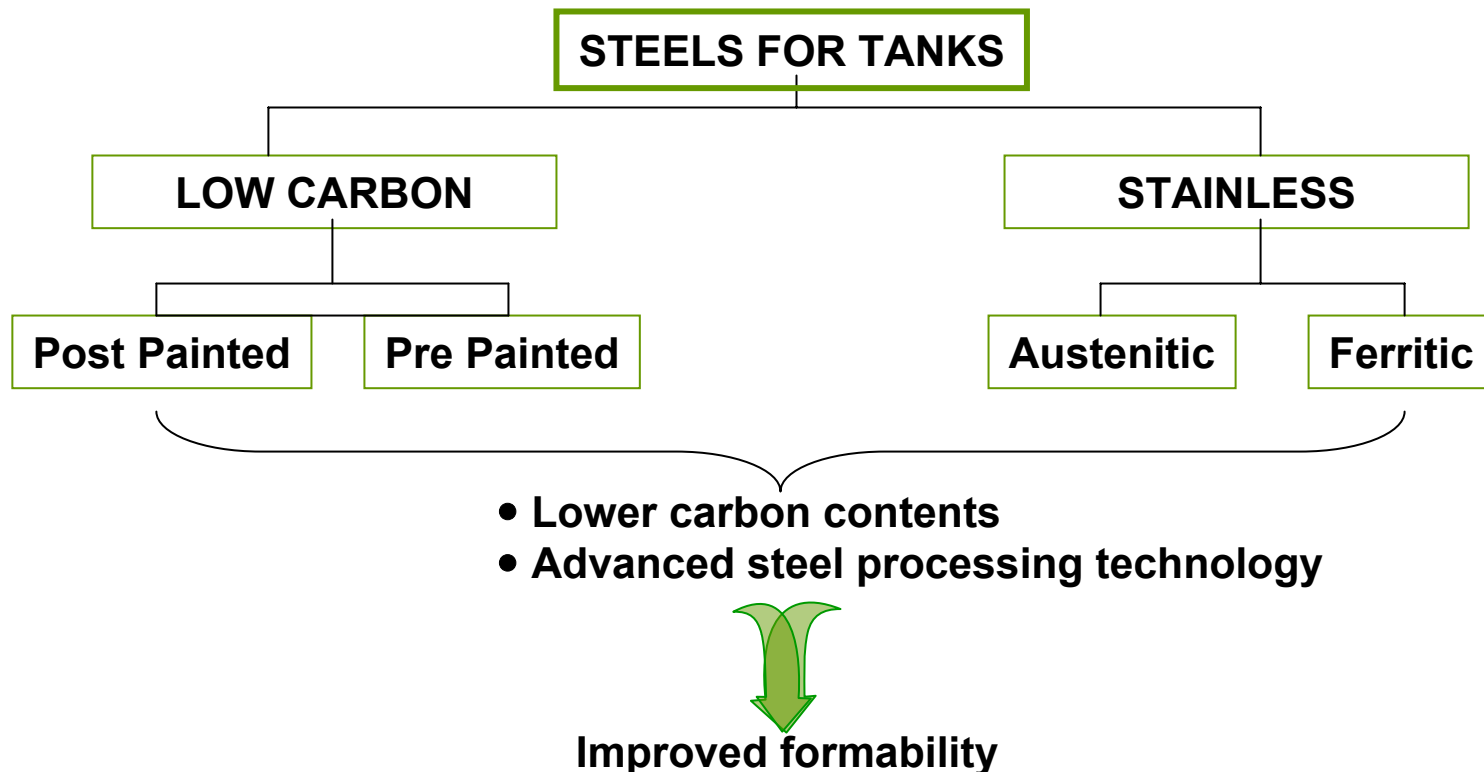



Enablers for Producing Complex-Shaped Steel Tanks

- New/improved stamping processes
 - Computer simulation techniques
 - Improved tooling materials
 - Improved stamping controls
 - Hydraulic presses
 - Variable cushion pressures
 - Dry film lubricants
- Emerging hydro-forming technology



Enablers for Producing Complex-Shaped Steel Tanks

- Advanced welding techniques

Roll Seam Welding

- Accommodates pre-paints
- Multi-axis 3D

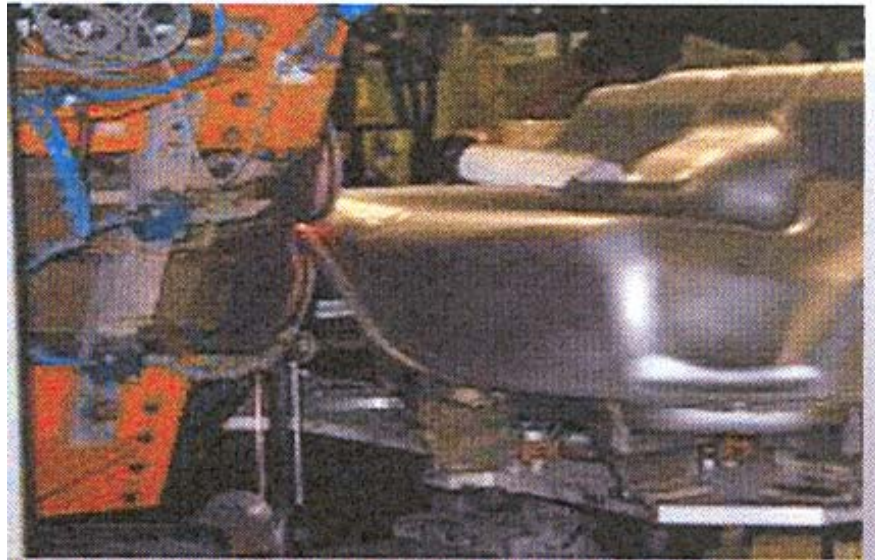

Plasma Welding

- Multi axis 3D
- Small flanges

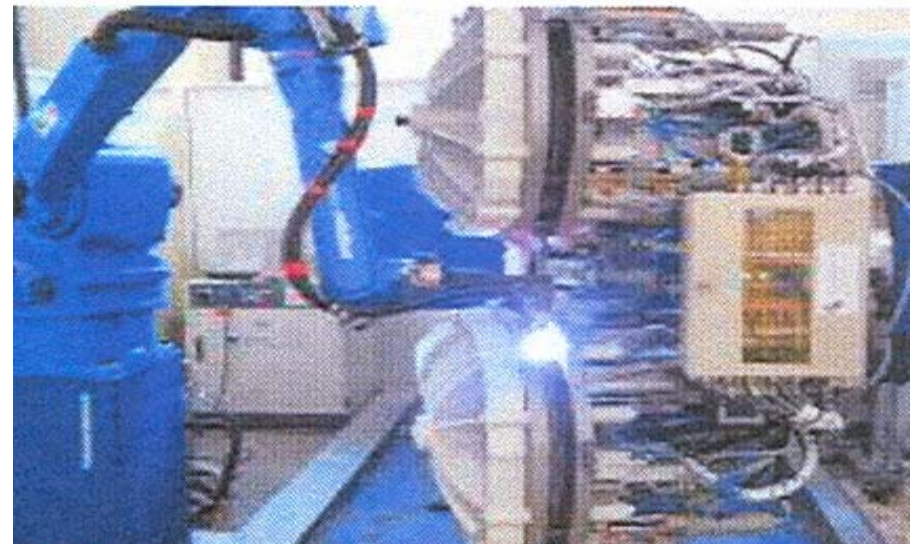

Photos: Courtesy of Dr. G. Pozgainer, Magna Steyr



Mass of Steel Tanks

- **For shell structures only**

- Mass of steel tanks is generally comparable with ‘virgin’ plastic tanks.
 - Constant steel wall thickness (typically 0.8 mm)
 - Variable plastic wall thickness (typically 5 -15 mm)
- But fully-saturated plastic tanks absorb fuel into the shell and increase their mass
 - About 4% for Multilayer tanks
 - About 8% for Monolayer tanks



Mass of Steel Tanks (Continued)

- **For tank ‘systems’**
 - A metal heat shield is often incorporated with plastic tanks
 - The heat shield is usually NOT NECESSARY for steel tanks and tank system mass can be reduced



Lower Tank-System Mass for Steel

EXAMPLE: Recent SASFT Feasibility Study Results

	Steel System		Mass Kg. (lb.)		
	Steel Thickness (mm)		Steel System	Plastic System (Shell & Shield)	Mass Savings With Steel
	<u>Top</u>	<u>Bottom</u>		<u>Virgin Shell</u>	
Option A	0.8	0.8	11.34 (25.0)	11.84 (26.1)	0.50 (1.1)
Option B	0.7	0.8	10.68 (23.5)	11.84 (26.1)	1.16 (2.6)
				<u>Saturated Shell</u>	
				12.29 (27.1)	0.95 (2.1)
				12.29 (27.1)	1.61 (3.6)

Because the steel tank also had higher fuel capacity
 – Resizing the steel tank to provide the same fuel capacity as the plastic version would save additional mass.



- Increased fuel capacity increases a vehicle's driving range
 - For alcohol-containing fuels, the driving range is reduced. Hence, any means of increasing fuel capacity is desirable.
- Three enabling factors for higher fuel capacity in steel tanks
 1. Volume effects of steel versus plastic shells
 2. Rigidity effects
 3. New welding technologies for reducing steel tank flanges



1. Volume effects of steel versus plastic shells

Example:

- Wall thickness of 0.8 to 1.0 mm compared to a thickness of 5 to 7 mm for a plastic tank

Average Tank Surface 1.5 m²: + 7.5 liters

- Reduced clearance with surrounding parts due to the absence of swelling

Calculated Seam length 4m: + 2.4 liters

- Optimized volume due to internal packaging of components, fuel and vapor lines

Estimate: + 1.5 liters

- Volume loss due to packaging constraints

Estimate: - 4.0 liters

Net Volume Advantage: 7.4 liters

A volume advantage of 7.4L
(1.95 gals) for a steel tank

Source: Dr. G. Potzgainer, Magna Steyer



2. Volume effects related to rigidity

Plastic tanks — “stand-offs” — detract from fuel capacity

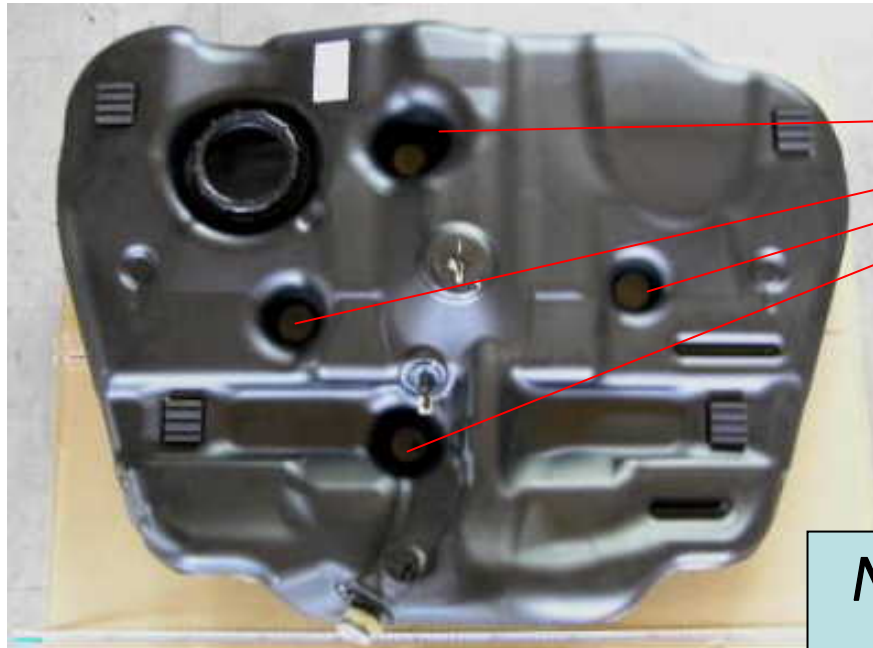

“Stand-offs”

**NO “STAND-OFFS” IN
RIGID STEEL TANKS
- VALUABLE SPACE
SAVED FOR FUEL**



3. Small flanges increase capacity

Audi A8



*Small flanges produced by
plasma & MIG welding*

BMW 3 series





- A recent SASFT comparative design study
 - Steel design versus plastic design
 - Saddle tank shape
 - Steel tank met same engineering requirements

FUEL CAPACITY RESULTS, liters (gals)

<u>Steel Tank</u>	<u>Plastic Tank</u>	<u>Increase</u>
85.16 (22.5)	79.46 (21.0)	5.7 (1.5)/7%

*Steel tanks have
a fuel capacity
advantage*



Durability of Steel Systems

- Many ‘steel systems’ are now available to suit different preferences globally

Steel Systems Selected for External and Fuel Corrosion Testing

ID Number	Bare Steel	Metallic Coating	Surface Exposed to the Test Fuel
Pre-painted category of steels			
1	Low carbon steel	EG Zn-Ni Metallic coating	Pre-paint (with Cr ⁺⁶)
2	Low carbon steel	EG Zn-Ni Metallic coating	Pre-paint (without Cr ⁺⁶)
3	Low carbon steel	Hot dip galvanized Metallic coating	Pre-paint (without Cr ⁺⁶)
4	Low carbon steel	Hot dip aluminized Metallic coating	Pre-paint (with Cr ⁺⁶)
5	Austenitic stainless	None	Steel + inorganic coating
Post-painted category of steels			
6	Low carbon steel	Hot dip terne Metallic coating	Phosphate (3mg/m ²)
7	Low carbon steel	Hot dip Tin-Zinc Metallic coating	Cr-free resin (300mg/m ²)
8	Low carbon steel	Hot dip Aluminized Metallic coating	Chromate
9	Ferritic stainless steel	None	Bare steel
Bare steels category			
10	Austenitic stainless	None	Bare steel

Results of external corrosion testing (Cyclic and Salt Spray testing) showed no perforation and durability beyond 15 years or 150,000 miles



Durability of Steel Systems

• External corrosion tests

- Neutral Salt Spray (ASTM B117)
- Cyclic Corrosion Tests (SAE J2334) – 160 cycles (~20 yrs)

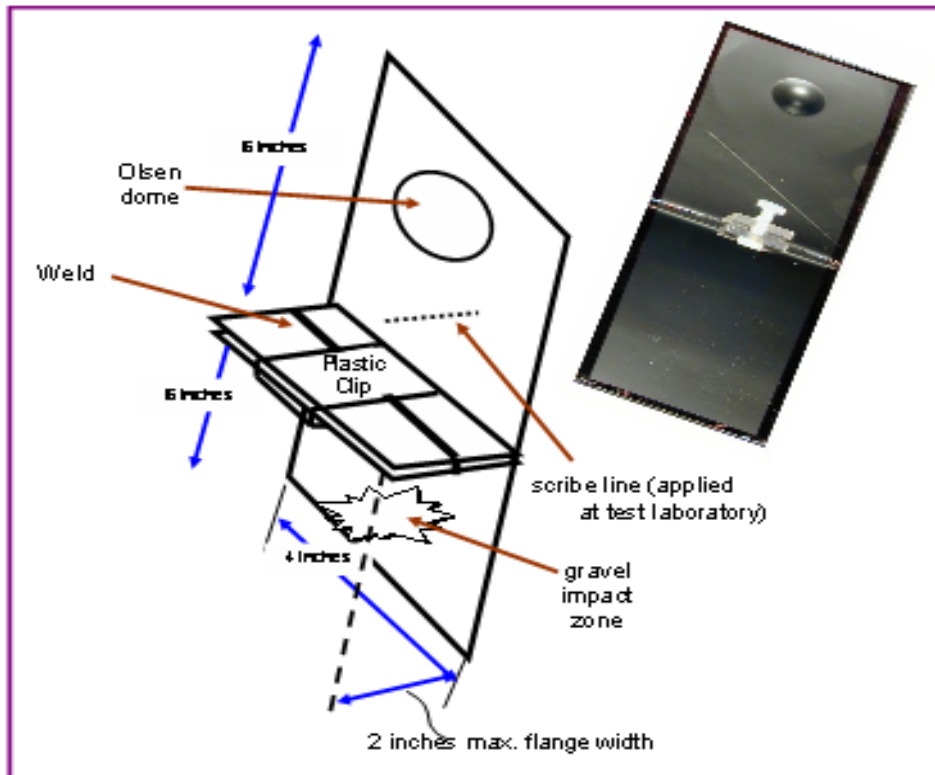

RESULTS:

- Some localized rusting on some steel systems
- Maximum pit depth
 - 10% one steel system
 - 10-20% two steel systems
 - 0% remaining steel systems

Above 15 year resistance to road salt environment and gravel infringement.



Durability of Steel Systems

• Internal corrosion tests

- Resistance to CE10A fuel evaluated in unique cup tests

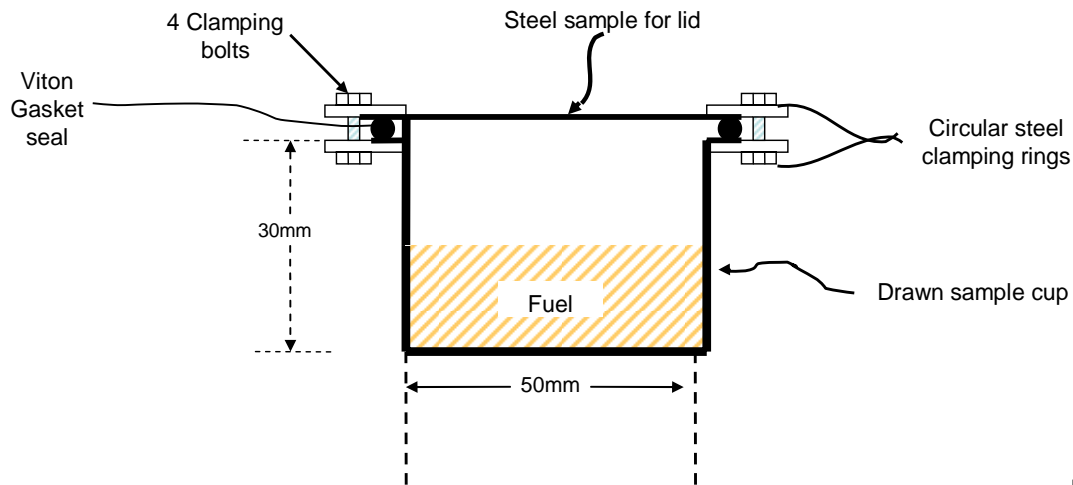

Blank diameter	=	98 mm
Punch diameter	=	50 mm
Die radius	=	3 mm
Clamping torque	=	1.1 newton-meter (10 inch pounds)
Draw depth	=	30 mm

All 10 steel systems showed effective corrosion resistance.

The perception that steel is not durable is FALSE



Durability of Steel Systems

- Additional studies are underway to test 10 different steel systems in alternative fuels.

- **Alcohol fuels (with water) at 60°C**
 - E10A
 - E22A
 - E85A
- **Bio-diesel fuels (with water) at 90°C**
 - B10 Blend of RME & SME
 - B20 SME
 - B20 AFME (Animal Fat)
 - B90 SME

Results expected in late 2008



Evaporative Emissions

- Steel is impermeable to gasoline, alcohol, diesel, and bio-diesel
 - Ideal for low evaporative emission requirements

Steel Fuel Tanks — the choice for PZEV

*Steel Fuel Tanks . . .
the choice for PZEV
vehicles*

California Air Resources Board:

— Certified gasoline PZEV
models

- 14 in 2003
- 23 in 2004
- 29 in 2005
- 40 in 2006

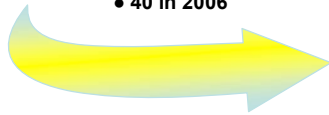

CARB PZEV certified vehicles for 2006				
Company	Model Year	Model Name/Type	Emission Rating	Tank Material
	2005	Escape - Hybrid - 2WD, 4WD	ATPZEV	Steel
	2005	Focus - Wagon - 2X3/2X4/2X5	PZEV	Steel
	2006	Fusion	PZEV	Steel
	2004	Sebring - Sedan	PZEV	Steel
	2004	Stratus - Sedan	PZEV	Steel
	2005	325C1 - Coupe	PZEV	Steel
	2005	3251 - Sedan	PZEV	Steel
	2005	3251 - Wagon	PZEV	Steel
	2004	Civic - Hybrid	ATPZEV	Steel
	2004	Accord - EX/LX Sedan	PZEV	Steel
Hyundai - Kia 	2005	Elantra - GLS & GT	PZEV	Steel
	2005	Spectra - 2.0L	PZEV	Steel
	2004	Mazda 3 - 2.0L/2.3L	PZEV	Steel
	2006	Mazda 6 - 2.3L	PZEV	Steel
	2006	Tribute HEV 4WD	ATPZEV	Steel
	2005	E350 - 3.5L	PZEV	Steel
	2006	Mariner HEV 4WD	ATPZEV	Steel
	2006	Milan	PZEV	Steel
	2004	Galant DE & ES2.4L	PZEV	Steel
	2004	Altima 2.5, 2.5S, 2.5SL	PZEV	Steel
	2004	Sentra 1.8, 1.8S	PZEV	Steel
	2004	Legacy 2.5 GT Sedan	PZEV	Steel
	2004	Legacy 2.5 GT Wagon	PZEV	Steel
	2004	Legacy L Sedan/Wagon	PZEV	Steel
	2004	Outback Ltd Sedan/Wagon	PZEV	Steel
	2004	Camry LE, SE or XLE	PZEV	Steel
	2004	Prius - Hybrid	ATPZEV	Steel/plastic bladder
	2004	S60 2.4 Sedan	PZEV	Steel
	2004	V70 2.4 Wagon	PZEV	Steel



Evaporative Emissions

- Total permeation (HC and Ethanol) in plastic systems increases with low ethanol additions

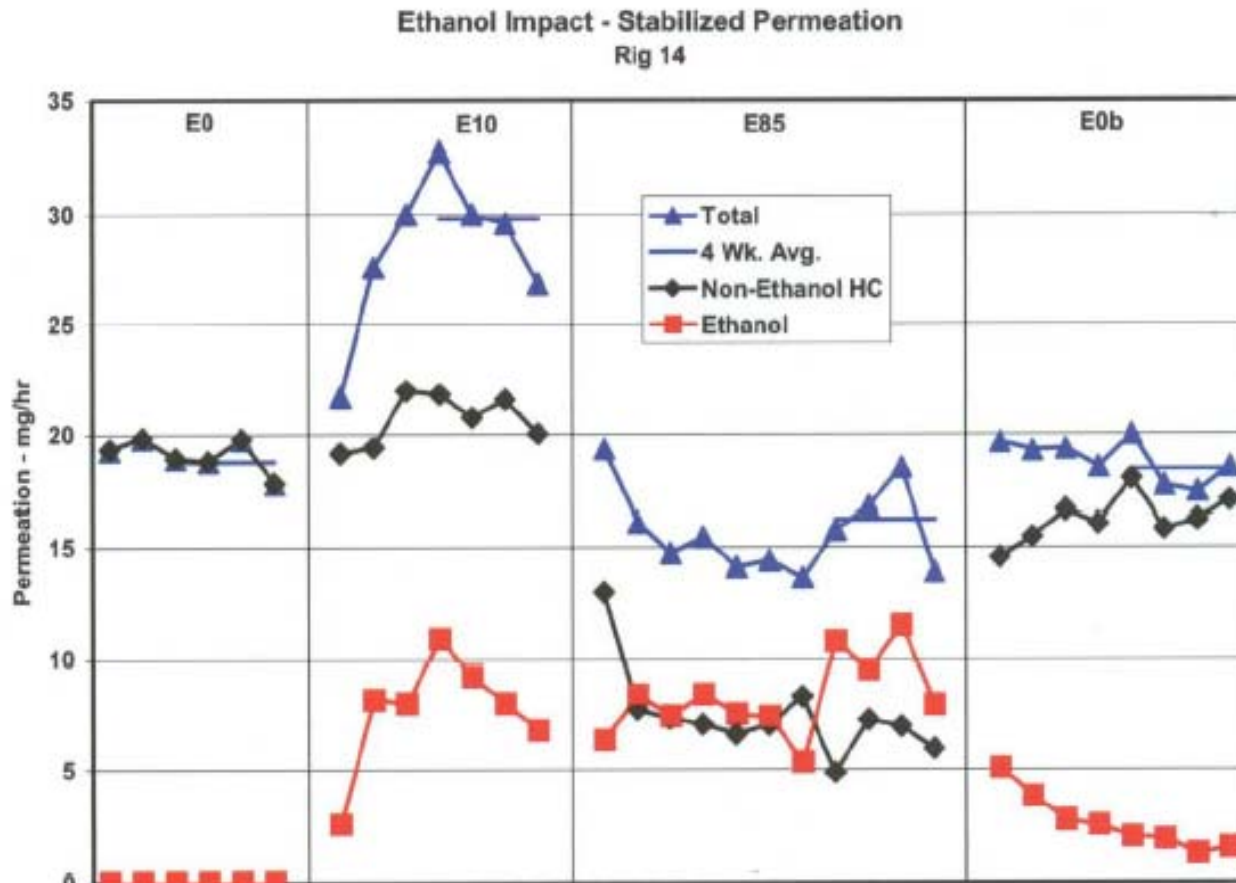

Source: Coleman Jones, GM presentation at ITB Conference (March 2, 2007)



Evaporative Emissions

- Permeation in plastic can be exacerbated by the presence of water in alcohol-containing fuels

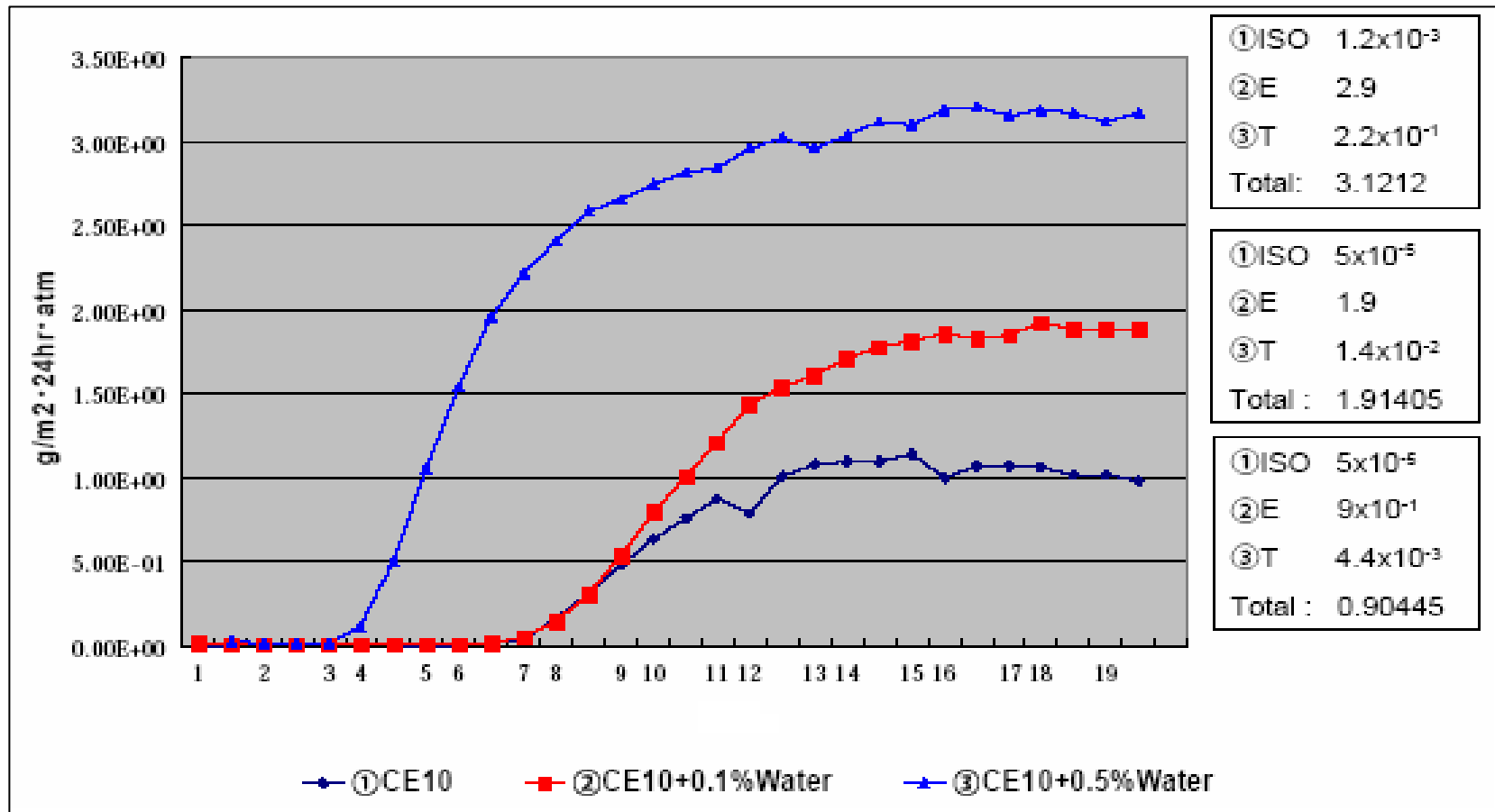

Source: GTR TEC, JSAE Exposition May 24, 2007



Evaporative Emissions

- For fuels containing $> 10\%$ alcohol modifications to the plastic fuel tank are likely

Necessary Modifications

(Otto Engines)

Ethanol Content in the Fuel	Carburetor	Fuel Injection	Fuel Pump	Fuel Pressure Device	Fuel Filter	Ignition System	Evaporative System	Fuel Tank	Catalytic Converter	Basic Engine	Motor Oil	Intake Manifold	Exhaust System	Cold Start System
$\leq 5\%$	Not Necessary	Not Necessary	Not Necessary	Not Necessary	Not Necessary	Not Necessary	Not Necessary	Not Necessary	Not Necessary	Not Necessary	Not Necessary	Not Necessary	Not Necessary	Not Necessary
5 ~ 10%	Probably Necessary	Not Necessary	Not Necessary	Not Necessary	Not Necessary	Not Necessary	Not Necessary	Not Necessary	Not Necessary	Not Necessary	Not Necessary	Not Necessary	Not Necessary	Not Necessary
10 ~ 25%	Probably Necessary	Probably Necessary	Probably Necessary	Probably Necessary	Probably Necessary	Probably Necessary	Probably Necessary	Probably Necessary	Probably Necessary	Probably Necessary	Probably Necessary	Probably Necessary	Probably Necessary	Probably Necessary
25 ~ 85%	Probably Necessary	Probably Necessary	Probably Necessary	Probably Necessary	Probably Necessary	Probably Necessary	Probably Necessary	Probably Necessary	Probably Necessary	Probably Necessary	Probably Necessary	Probably Necessary	Probably Necessary	Probably Necessary
$\geq 85\%$	Probably Necessary	Probably Necessary	Probably Necessary	Probably Necessary	Probably Necessary	Probably Necessary	Probably Necessary	Probably Necessary	Probably Necessary	Probably Necessary	Probably Necessary	Probably Necessary	Probably Necessary	Probably Necessary

- Not Necessary

- Probably Necessary

Source: Coleman Jones; Presentation to SAE (Detroit Chapter) November 16, 2007

No modifications are necessary for steel tanks.



Sustainability/Recycling

- Steel tanks are fully recycled using an existing infrastructure.
- In North America, virtually all plastic tanks are landfilled.

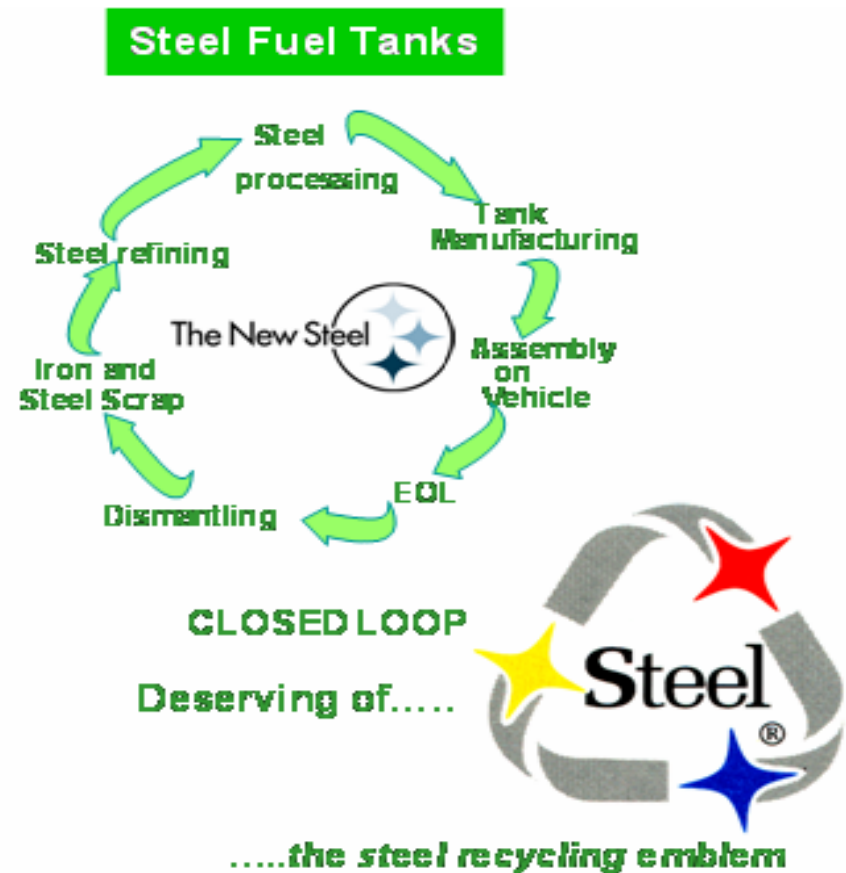
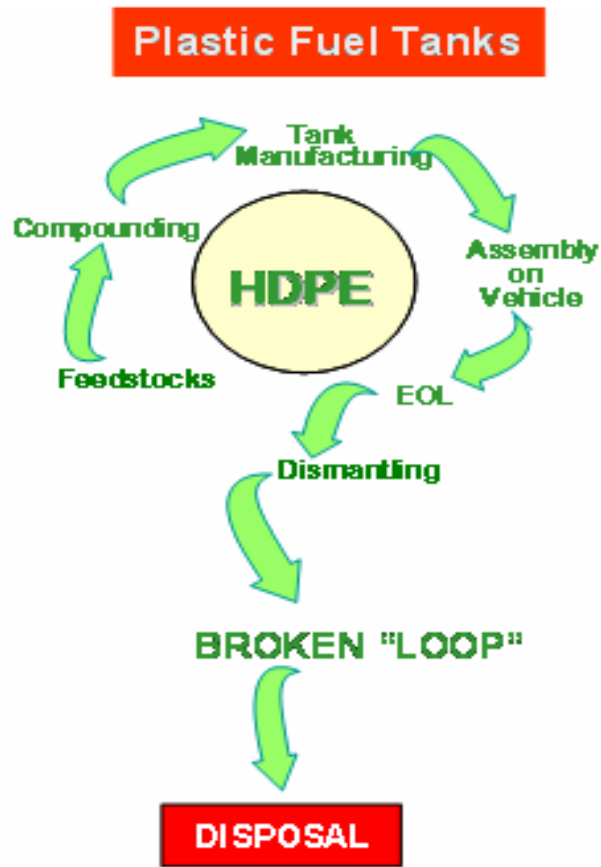



Sustainability/Recycling

- **Steel tanks allow compliance to Europe EOL regulations**

The **End Of Life (EOL)** legislation of the **European Union** defines more stringent targets for recycling after utilization of the cars

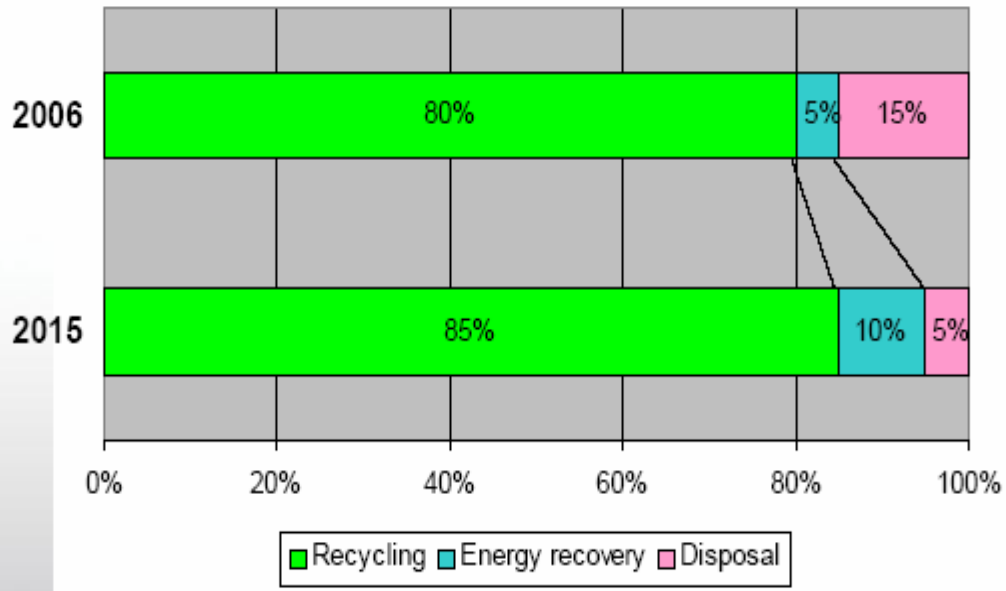

Source: Dr. G. Potzgainer, Magna Steyr

Recycling :

Energy Recovery :

Disposal :

Reuse of Parts, Material or Raw Material Recycling

Burning and utilizing the intrinsic energy

Landfill or Thermal Conversion



- Landfill disposal of plastic tanks depletes land resources

Magnitude of Plastic Tank Disposal

In 2004, 303 million vehicles will be on the roads in Europe (J.D. Power PARC data)

Assuming 92% of the vehicles have plastic tanks, or at the end-of-life, they are:

- crushed to 50% height
- landfilled

... A disposal mountain results

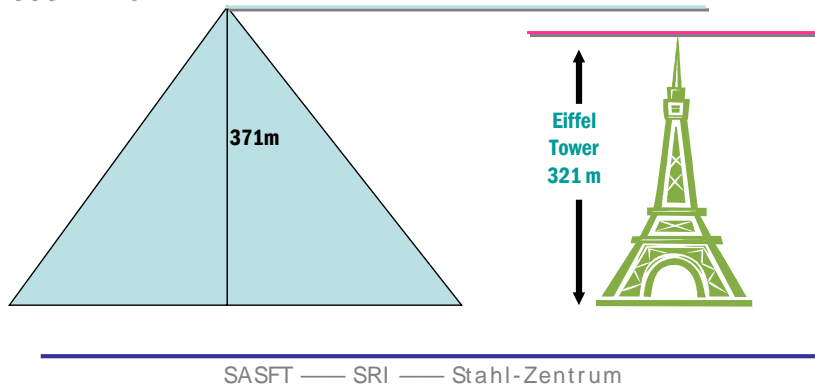

Steel tanks are 100% recycled —no impact on land resources



Magnitude of Plastic Tank Disposal

- In 2014

- 303 million personal vehicles will be on the roads in Europe (West and East)

(J.D. Power Vehicle PARC data)

- Assuming 92% of these vehicles have plastic tanks

(ITB Group - European production estimate for 2003)

- These tanks placed end-to-end would stretch:

- 229,000 km
 - almost 6 times around the earth





- Although steel tanks have lost market share to plastics in the 1990s
 - *Steel tanks are increasingly cost competitive.*
 - *New steels/technologies allow steel tanks to meet the demanding requirements of automakers and environmental legislators.*



- Key features of steel fuel tanks
 - Very cost competitive
 - Especially for high tech applications (e.g., PZEV)
 - Higher oil/resin prices in future will likely increase steel's cost competitiveness
 - High design flexibility
 - New steels/manufacturing technologies
 - Competitive in mass with plastics
 - Lower mass when heat shields are removed



Summary/Conclusions

- Key features of steel fuel tanks
 - Durable to road environments and aggressive CE10A fuels for beyond 15 years/150,000 miles
 - Better fuel capacity for same engineering space
 - Preferred for low evaporative emissions (PZEV)
 - Sustainable
 - 100% recycled using existing infrastructure
 - Landfill resources are preserved
 - Steel — the Green material



BACK UP SLIDES



Strategic Alliance for Steel Fuel Tanks (SASFT)

- Global alliance for the market development of steel fuel tanks
 - Steel tank manufacturers
 - Equipment suppliers
 - Steel suppliers
- Organized by American Iron and Steel Institute (AISI)
- Cost sharing organization
- Started in 2000
- Typical projects
 - Market analysis
 - Durability optimization through corrosion studies
 - Information sharing/communications



Steel Tank Manufacturers

Aethra Componentes Automotivos	(Brazil)
Allgaier Automotive GmbH	(Germany)
Dong Hee Industrial	(So. Korea)
Fuel Systems LLC	(USA)
Harley Davidson	(USA)
Martinrea International	(USA)
Spectra Premium Industries	(Canada)
Unipart Eberspacher	(UK)
Unipres Corp.	(Japan)

Steel Tank Equipment Suppliers

The Magni Group	(USA)
Soutec Soudronic	(Switzerland)

Steel Suppliers

ArcelorMittal	JFE Steel
AK Steel	Material Sciences Corp.
Nucor	Nippon Steel Corp.
Severstal North America	Nisshin Steel
U.S. Steel Corp	North American Stainless
	POSCO
	Sumitomo Metal Industries
	ThyssenKrupp Steel



For More Information

Contact:

Peter Mould
Strategic Alliance for Steel Fuel Tanks (SASFT)
prmould@comcast.net
810.225.8250